

**YJH (A) SERIES FUEL OIL LIQUID HEATER
OPERATION MANUAL**

18kw

YJH-Q18A

采用挥发雾化技术，燃烧稳定，热效率高，能够在-41℃以上的超低温环境下正常启动运行。



体积小、功率大、易安装，超低温可迅速启动发动机！

特点：

- 采用自动控制，可将循环介质温度自动稳定在60℃-80℃之间。也可根据用户实际需要调整供油量，使燃油消耗量随循环介质温度变化自动调整，降低油耗的同时，保证了冷却液容量略小的车型的取暖需求，也延长了加热器的使用寿命；
- 结构优化设计，相较于同发热量机型相比结构更加紧凑，排放更低；
- 全铝机身结构，热交换效率更高；
- 结构紧凑、体积小、维修方便；
- 燃烧效率高，低能耗，性能可靠，升温快；
- 具有高海拔补偿装置，保证海拔5000米和其他恶劣条件下正常使用；
- 具有安全保护和自我诊断功能；
- 加热器尾气排放符合最严格欧洲尾气排放标准；
- 关键部位采用防水插件，整机满足IPX6防水等级；

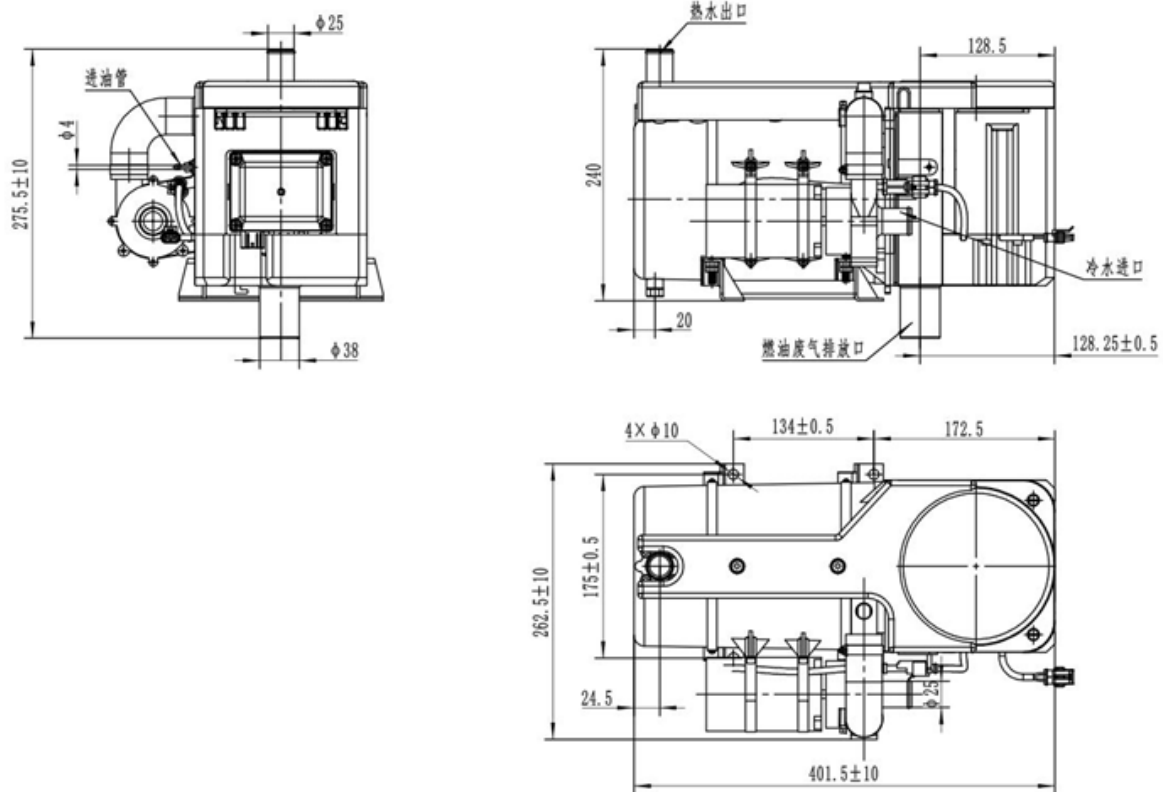

安装尺寸图

技术参数:

项目	参数	型号	YJH-Q18A
热流量 (kW)			18
耗油量(L/h)			2.3
工作电压(v)			24
功耗 (W)			180
重量 (kg)			13.5
外形尺寸 (长×宽×高) (mm)			402×263×275
适用范围	重型卡车、特种车、工程车、客车等水冷发动机低温启动；与散热器配合后可独立为驾驶室取暖及前风挡玻璃除霜或方舱、车厢采暖		

1. Service condition and technical parameters

- Storage temperature: -55 °C -70 °C ;
- Operating temperature: -40°C -50°C (Note: the automatic control box of this product is not suitable for working in the temperature above 50 °C for a long time. If use this product in Equipment such as ovens, please place the heater control box in the low temperature environment outside the oven);
- Water constant temperature 65 °C -80 °C (adjusted according to demand);
- The product cannot be immersed in water and can't wash directly with water and place the control box installed in the position where will not be watering; **(please customize if need water proof)**
- This product is recommended to use appropriate low temperature of diesel or kerosene, or diesel will paraffin in oil pipeline which cause that the heater does not work. Gasoline cannot be used for fuel;

above 5 °C	Above -5 °C	Above -15 °C	Above -30 °C	Above -40 °C
0 # diesel	10 # diesel	20 # diesel	35 # diesel	50 # diesel

- The working voltage of this product is DC12/24V. If voltage is abnormal, the automatic control of heater will protect to not work (see error code table). Power generally use car battery, when AC power supply, it is better to use regulated power supply and pay attention that the power supply must be greater than the starting power consumption of heater. It is recommend to use the power supply which is greater or equal to 400W. when the power is not stable, the automatic control board may not operate properly;
- Operating Altitude: civilian altitude ≤ 3000M, military grade products at an Environmental altitude ≤ 5500M;
- Normal working speed :0-100KM / h;
- Suitable for pre-warm up of a variety of water-cooled engines and vehicles heating for below 7M;

Please make sure that your service condition is in line with the product use conditions.

2. Structure and working principle

As shown in figure 3, the native structure is divided into three parts combustion head, combustion chamber and heat exchanger as well as independent circulation pumps. while combustion head includes burning motor, pump (YJHA external pump) and combustion supporting wind rotor which is responsible for providing fuel and combustion air. Motor, pumps and small wind rotor install coaxially while air flow and oil provided change in the equal ratio to ensure that work at steady speed in different voltages; burning body parts include the center body connectivity, deflector plate, the combustion chamber, ignition plugs, fuel volatilization net, which guaranteed supply of fuel and combustion air with the sound and stable combustion and heat exchanger transfers heat to the cycle of burning liquid. These three parts Install in series and can be separated when split for easy maintenance. Parts of the machine externally fixed and connect components of heater by connecting harness.

Ignite piston (6) to electrify to heating in working. When it reaches the rated temperature, magnetic pump (2) and motor (3) electrify to work. Fuel is sucked to volatilization net (7) by pump (2). The fuel immediately evaporates and mixes with combustion air sending by wind rotor (4). Gas mixture combusts rapidly with the ignition plug in the combustion chamber (8) under high temperature. Meanwhile Combustion exhaust gas displace from the exhaust pipe in the heating exchanger (10) after circulating the liquid. with the heat exchanger temperature rising, the flame detector (9) takes action and the control circuit cut off the ignition plug Electricity; heater combust normally and the heating circulating fluid in the heat exchanger (10) circulate in the engine heating system with the help of pump (1) to warm up the engine and take heating. When Shutdown, the control circuit shut off the solenoid valve firstly, the heater stopped burning, the temperature of heat gradually reduce. In about 3 minutes, the flame detector detects that engine stops after the machine cooled and the heater ceases to work. It is prohibited to shut off the main power in normal operation to prevent to cause that the heat in the heater cannot be shed, and the heater damage.

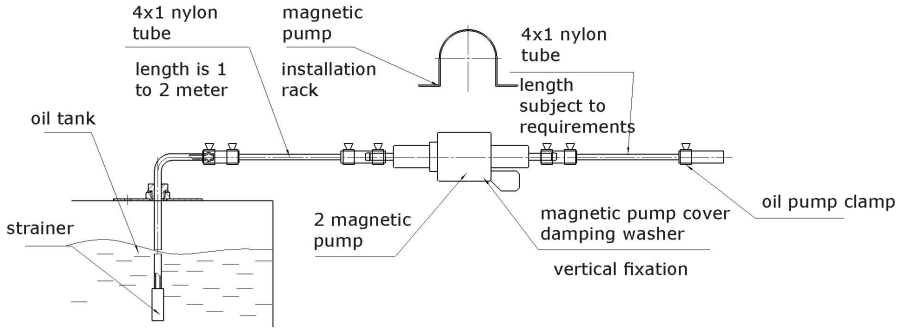
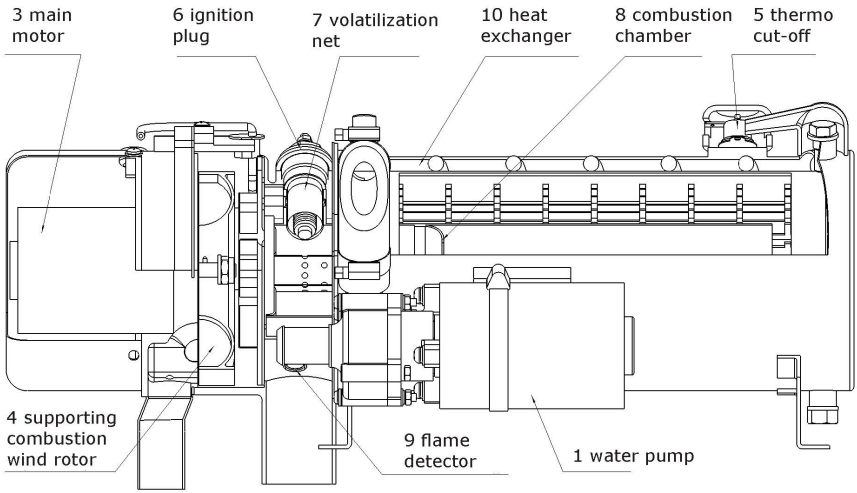

Figure 3 YJH-QA principle

3. Installation instruction

In order to maximize the effectiveness of your heater and use it effectively for long-term, you must follow the instructions in installation and heating.

- **Heater mounting:** the heater can be arranged internal and external of the car with its horizontal axis ($\pm 5^\circ$). The heater should be arranged in less vibration position and should not be arranged nearby the engine. In order to make a good loop pipe, the location of heater pump should be as low as possible and must be below the inlet of the water tank. Heater cannot be arranged in the vicinity of the wheel to prevent mud getting into the heater, and preferably arranged in the equipment compartment. Heater should be screwed directly to install in the vehicle body with four M8 Plugs. When the body thin steel plate needs add stiffening plate to strengthen, the sizes of hole see figure. Heater can also be used in the car chassis on the lifting angle, see Fig.
- **Heater fuel pipe installation:** the fuel of heater is diesel fuel or kerosene and can directly connect the vehicle fuel tank. Note that the surface height between fuel tank and the heater cannot exceed $\pm 500\text{mm}$. When the tank is too far away from the heater (over 10M) or when it is gasoline vehicle, it requires a separate fuel tank. Tubing used $\Phi 6 (4) \times 1$ nylon tube (or hose) and special connectors. Pipe joints must be tightened, the tubing cover protect casing and fix on the body. Since the fuel consumption is small, so the sucking speed of oil is slow and the heater takes long time for first fire burning oil. The length of pipeline between electromagnetic pump and tank oil is no more than 1M and the pipe length between pump and heater is not longer than 8M. Electromagnetic pump should be installed horizontally.
- **Combustion air and combustion exhaust gas** must be unobstructed intake and exhaust and the inlet and outlet of combustion air in the heater cannot directly facing the traffic direction. Combustion air inlet and outlet cannot have block object within 500mm in the bottom or it will affect the normal combustion. When the Heater arranges in the chamber, the combustion air inlet and exhaust outlet must connect to the open air out of the chamber. Exhaust gases are harmful to our health and combustion air consumes oxygen, that they cannot

be connected into the compartment. Gas outlet can connect a corrugated metal hose which is no longer than 2M and turn angle is not greater than 180 °. Exhaust gas can be used to heat oil pan.

- Heater pump can be removed from the layout of the machine and set separately, and pay attention that the pump outlet should be above the horizon; water pump inlet connects to the hot water outlet of the engine, such as the warm air outlet (Note: cannot connect to the pipeline between the thermostat and the engine cooling water tank); Hot water outlet of heater connects to the return pipe of engine. Water heater shall not have any Bends which impact on circulation; water pipe should add rubber sleeve to protect when go through the car body; turning at right angles must use elbow. Installation example is shown in Figure.
- Please tap a square hole on the instrument panel according to the figure, and plug the switch plate into the square hole as well as fix the control box near the heater where facilitate to repair, plug the wiring harness tightly. Control box and heater should be connected with transition harness according to the drawing. The harness should add rubber protective sleeve when go through the body and the sleeve should be fixed tightly. The native negative ground, please make sure good contact of negative, otherwise the heater may not be reliable to work, and for dangerous goods vehicles transportation, should pay particular attention to good contact and prevent sparks. Note: You can choose Insulation pad installation.
- Please carefully double-check that the installation is correct before starting, especially whether the circuit connection is correct, short circuit or reverse polarity, the heater is firmly fixed, and whether there is different material go into the combustion air inlet and exhaust exit, pipe valve is open, with or without fill anti-freeze.
- Heater shall not be placed near any combustible or explosive hazardous materials.

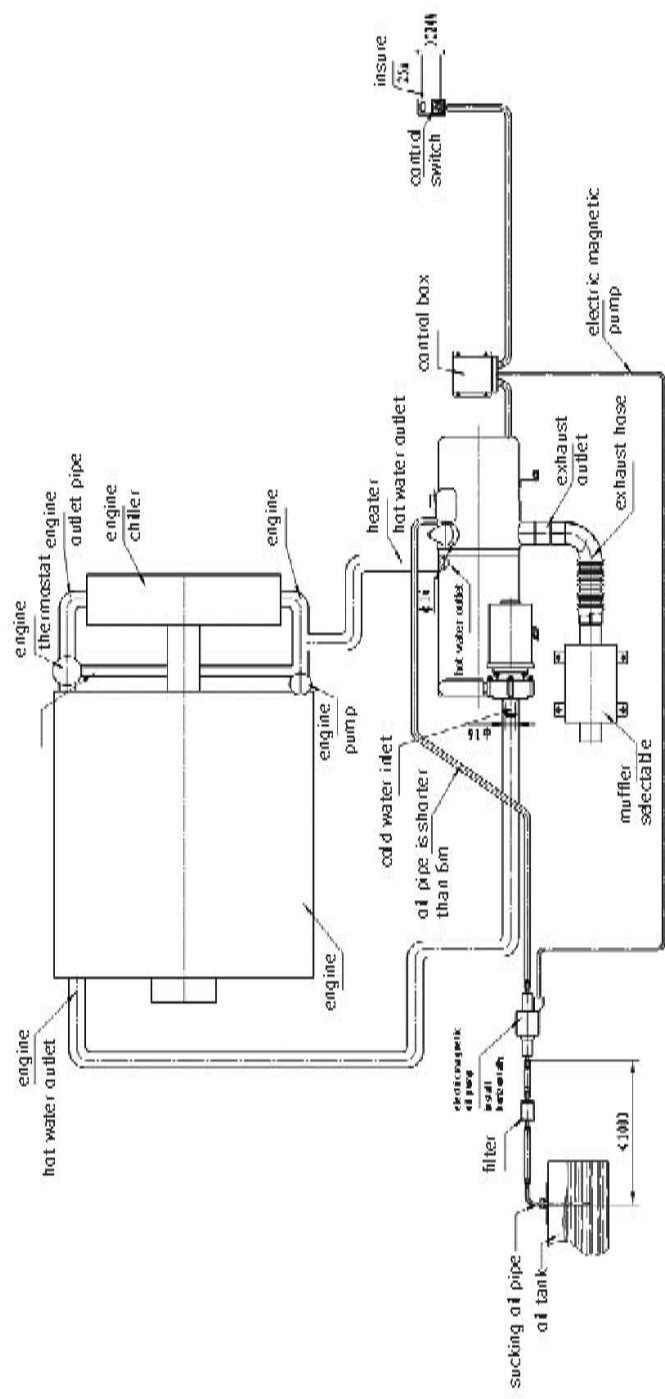

NOTE: The hot water outlet of engine can't connect with the outlet of engine as the hot water of the heater will go through the engine and go back to the heater and can't heat the engine water cover.

Figure 4 YJH-A instruction drawing

3. Usage

Control switch board as shown in Figure, is a light car wane switch with two indicator lights of green power indicator light and red state indicator light separately. status indicator indicates the work condition of heater and fault codes. Only pump work when press the switch to first gear, and the heater does not work just only use waste heat of engine for heating.

Then press the switch to turn on the heater while the pump is also working; the power indicator light and heater will measure the battery voltage of the car, If the voltage is below 20V (12V heater is 10V) or above 32V (12V heater is 16V), heater will alarm and indicate a failure; if heater battery is normal and the pump operate, when the water temperature is below 65 °C , the control circuit will control heater to work automatically according to the operation procedure. Firstly pre-heat the ignition plug for about 30 seconds, then the main motor and solenoid valve charge, the heater starts burning heating; if the heater operate normally in a specified time and the status light indicate, in the meanwhile glow plug shut off power, the temperature of circulating fluid gradually rose; if the heater doesn't work within the specified time and ignite again the heater again. If heater is still not working properly twice or has been working but the control circuit fails to detect, control circuit will automatically stop the heater, and automatically detecting heater can't find the reason then the buzzer (optional) will call; and then the main motor blow about 90 seconds, the status light indicates the fault condition.

Heater runs into the combustion heating state. When outlet water temperature of the heater reaches 60 °C , the heater uses frequency pulse width modulation to gradually reduce the heat to reduce fuel consumption; when the water temperature is up to 80 °C , the heater will stop, the main motor delay to work to cool the heater; when the main motor stop working, the status indicator will turn off. When the heater temperature sensor senses the water heater temperature is lower than 65°C , the control circuit will automatically control the heater to work, and move in circles.

Pres the switch to a stop position when the it doesn't need heating, power

indicator light turns off and the heater stops burning, but this time the status light is not extinguishing immediately, it will be delayed about 3 minutes until the heater is cooling off; when the status light is on, it is prohibited to shut off the vehicle power, or the heat in the heater cannot shed out and could easily lead to heater failure.

For YJH (A) series heater working in high altitude (3000M above) regions for long term, it can adjust altitude compensation knob of oil and gas ratio to adapt to different environmental requirements.

The machine control circuit has a number of fault identification functions. The heater continuously detects working status, including battery voltage and state of the combustion; the heater in the burning process cut control circuit will automatically re-ignites. When the heater have a fault or fail supply of Electricity or oil for vehicle, the heater will automatically shut down while switch indicator flashes according to binary code, indicating the type of fault. Indicator flashes 5 each time and the flashing includes two lengths of time, long time is 1S, represent 1 and short time is 0.2S, represent 0, interval is 0.5S, each flash interval is 2.5S, a total of $2^5 = 32$ types of fault status, see fault Code table.

With timer and remote control, heater can start remotely and timely.

电气元件列表

BL	点火塞	M	主电源
Bt	水温传感器	JT	热保险
BT	火焰传感器	ML	水泵电机

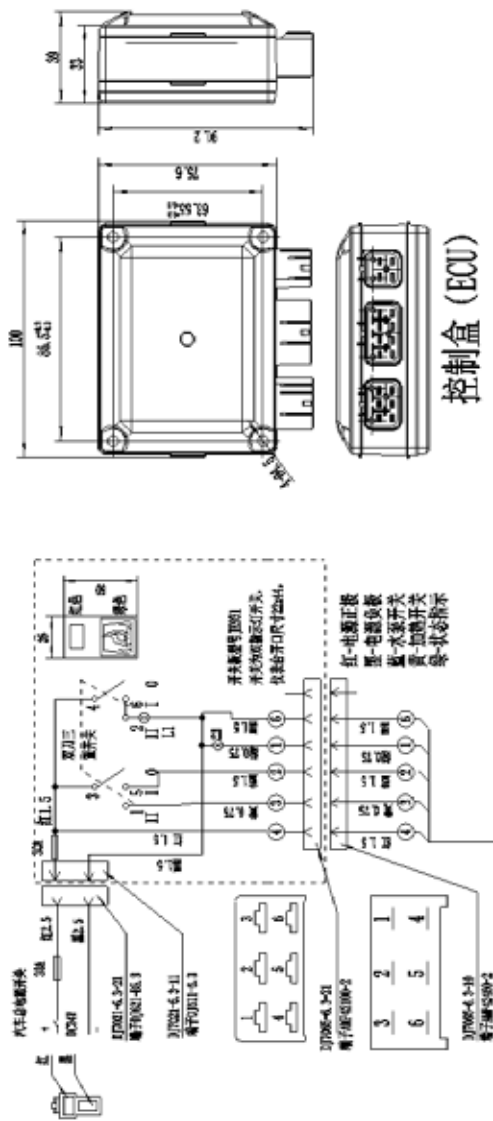

功能定义:

- 黑-水温传感器 (热敏电阻型, 不分正负)
- 白-燃烧传感器

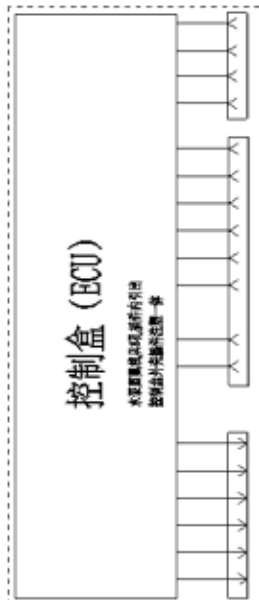

开关板至控制盒线束连接

XL:DJ7063-2,3-21 (图)

5. Troubleshooting and maintenance methods

Fluid heaters can't be full of water in the pipe when change ice-free liquid or add water each time. If there is air, it is prone to poor circulation of pipeline which may cause the engine water tanks Boil, heater is too hot and other heat pipe is not hot; firstly open the engine of this case to force circulation, continue to add antifreeze liquid, and open switch of the gas heater and pipe to release air in the pipeline, generally you can solve the problem of poor circulation pipe.

Also note that the pipeline must not have any big bend, or pipeline cannot cycle. Every year when first to use the heater, please check the status of the heater, make sure that the heater water valve is open, the turning of the heater should be flexible, combustion air inlet and exhaust emissions have no mud and other things, inlet and exhaust gas smoothly, clean up the exhaust and extend the carbon and other items in pipe. When in the season of not using the heater, please open the heater for 15 minutes every month to keep the heater in good condition. When the heater installs and work for the first time, as there are no oil in the heater oil pipe, the heater may not work properly for the first time, it can work properly after a few times.

Glow piston and fuel distribution networks generally do not need to clean, but if the heater drip and smoke and Cannot combust, please remove the glow piston and volatile net and clean the carbon on the net, re-install the heater in place and open the heater.

If the course of the circulation of water pipe in the heater is not smooth, the body temperature of the heater will be too high, then the manually reset hot fuse in the heater automatically disconnect, stop supplying oil and body gradually cool. If this happens, please check the water pipes of the heater are smooth, the pipes are flattened or not. Then press the central rubber cap of fuse reset button to reboot.

If the heater is bad ignition, please use the weak ignition.

Turn on the heater and the switch indicator is not light , check the main power is on or not, heater fuse is blown or not, harness contact is good, solid, control box is damaged or not.

For totally automatic control circuit, if the panel still can't work properly or status indicator randomly flash, please check the power supply is stable, regulated

power supply capacity is sufficient, the control box is not damaged; if the heater is not burning or stop burning, please check whether the heater can burn. If it can, please check if the flame sensor and control box is defective. Other faults please refer to fault indicator status troubleshooting.

If the heater is not burning or combusts insatiably, the exhaust does not smoke and drip, check whether the oil pump is blocked or the pipe is loose and leaking.

Heater burns and smokes, check the heater combustion air intake and combustion gas is typical, the exhaust tube with or without carbon emissions, clean up carbon deposits inside the heater. (Note: general heater is not suitable for the environment at an altitude of more than 3000M long-term).

If you have further questions, please contact our special service units and see contact information in the next section.

**II. Working voltage and temperature: DC24V
(or DC12V), -41°C — 50°C**

III. Control Panel



Fig. 1

From Fig. 1, we can see that there are four buttons on the control panel (⏻, OK, SET, ↑) and one displayer. All the buttons are touch switches with indicating lights. Here below are the functions of the buttons:

“⏻”, On / Off and log-out.

“OK”, to confirm the settings (a switch-over button for manual-control caloric value and auto control of caloric value)

“SET”, to set parameters and switch over the settings.

“↑” Adjust the set parameters

“⏻”, the red light is to indicate the power, which will be on once the controller is connected with the power.

“OK” “SET” “↑”, the green light is to indicate the “on” or “off”, if it is on, it means that the controller is started up and begins to work.

“OK” “SET”, the indicating light in the middle (in the shape of flame, in blue); if the light is on, it means that the heater is being working normally; if the light is flashing, it means that the heater suffers a default.

IV. On/Off

Once the heater is powered on, press “ ” then the heater is started. Under normal situation, the interfaces are shown in a good order like this:



Fig. 2



Fig. 3

When Fig. 3 is available, the heater is being working normally. If there is a default, you can see the interface as follows:



Fig. 4

If Fig. 4 is available, the “flame-shape” light (the blue light) will flash, which means that the heater suffers a default. (The default is not suffered by the controller).

After start-up, press “” long for shut-down. On the display screen, you can see “Being shut down, please wait.” and “Do not turn off the main power”. Since the shut-down needs to have the heater cooled down, it is not allowed to turn off the main power. Once the heater is shut down, the flame-shape light (the blue light) will be off and the displayer closes automatically.

V. Settings

1. Time setting

Power on the controller and long press “” to start the controller. On the display, you can see “Being powered on or standby” or “the heater is being working normally”. Then press “SET” to set the time. See Fig. 5.



Fig. 5

Press "↑" to select the value for the flashing items, (press "SET" to switch over the flashing items, once the expected value is selected, press "OK" to confirm the setting.

2. Set timing start-up

The same as the operation mentioned above, press "SET" to switch over to "set timing start-up", see Fig. 6.

(When leaving the factory, the timing start-up is at 06:30).



Fig. 6

Press "↑" to select the value for the flashing items, (press "SET" to switch over the flashing items, once the expected value is selected, press "OK" to confirm the setting.

3. Set constant temperature (for your option)

For FJH series heaters, constant temperature control is for your option.

The same as the operation mentioned above, press "SET" to switch over to "set constant temperature", press "↑" to get the value that you want and then press "OK" to confirm. After this, the controller will adjust the caloric value automatically according to the set temperature, which will keep the temperature constant.

Note: When setting the parameters, each parameter shall have its set value confirmed respectively by pressing "OK".

Once the setting is confirmed by pressing "OK", there will be a reminder like "the time has been set" or "the timing start-up has been set". That is the button "OK" can only confirm the set parameters one by one.

For example, if two parameters, the time setting and timing start-up setting, are to be set, it is mandatory to:

1. Press "SET" and "↑" to set the time, then press "OK" to confirm the time;
2. Press "SET" and "↑" to set the start-up time, then press "OK" to confirm the start-up time.

The parameters can not be set in one go, which can not be confirmed by "OK" in one go either.

VI. Timing start-up

When the heater is on, set the start-up time. (If there is no need to change the time after setting, a second setting is not required. That is the controller has a function of "power-off memory" --- after being powered off, the parameters will be saved). When heater is under "standby", long press "↑" to access to timing start-up. See the interface shown in Fig. 7.



Fig. 7

The first time (06:30) is the timing start-up while the second time (07:01:45) is the current time. When start-up time is available, the heater will be started automatically, which will be shut down automatically after working for 55 minutes in total. (The shut-down will happen when the total working time is 55 minutes, if the heater has a standby because of high temperature, the standby period will not be included in the 55 minutes) .

VII. Manually control caloric value of the heater (for your option)

For FJH series heater, the function “manually control caloric value of the heater” can be for your option.

Press “OK” to access to the interface “manually control caloric value of the heater”, press “↑” to adjust the caloric value. There are four different grades of caloric value, which are shown via the icon “■ ■ ■ ■”.

“■” is the first grade (the lowest)

“■ ■” is the second grade.

“■ ■ ■” is the third grade (the highest)

VIII. Wireless remote control (for your option)

Wireless remote control can be for your option according to actual demands. That is the heater can be under wireless remote control. The controller and the wireless receiving module shall be encrypted so that they will not be wrongly triggered. The remote control distance can be customized according to actual demands (the default distance is 100m at an open field).

Remote control: the heater shall be powered on, press the “ON” of the controller so the heater will be started; press “Off” of the controller or “standby” on HX-2, the heater will be stopped.

Note: If the remote controller is on, the heater can be stopped via remote control or pressing “standby” on HX-2; if the heater is started via HX-2 (press “standby” on HX-2), the heater shall be stopped by HX-2 (press “standby” on HX-2).

IX. Tips and troubleshooting

1. If “timing start-up” is required, the power of heater can not be turned off after the timing start-up is available; **therefore, the heater’s power can not be controlled by the vehicle key. It is suggested that the heater shall have its power supplied independently so that the power of other parts can be turned off when the driver leaves.**

2. Water-proof shall be highly cared about. Do not put a water cup near the display panel, otherwise, the controller will be damaged by water.

3. In order not get the buttons wrongly touched and triggered (like they are triggered when mopping the panel), **please long press “⏻” to power on or power off. When start the timing start-up, it is required to long press “↑”.**

4. If the power indicating light is not on after power-on, please check that whether the power is well connected. Besides, on the power positive wire, there is an inserted **insurance** for vehicle use. If the fuse is broken, there will be a short circuit or an over current.

5. The controller has a button-type battery CR2032, which will keep the time going when the storage battery is not available.

X. Installation Drawing

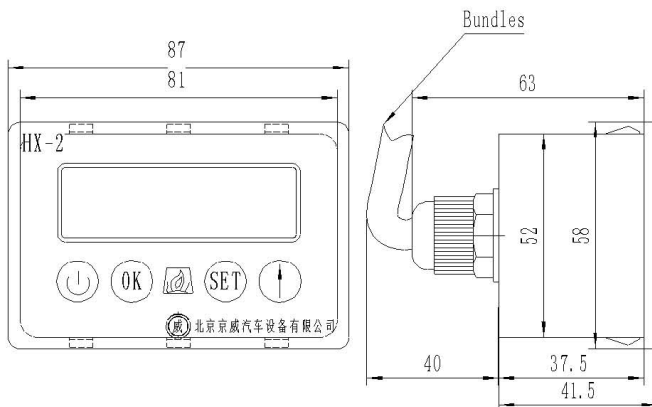

Note: 1. It is suggested that the reserved height under the instrument platform shall be more than 85 so that the installation will be more convenient.

2. It is suggested that the opening of the instrument platform shall be 81.5*52.5.

HX-2 Display Fault Code Table (The indicator light flashes in a binary code to indicate the type of fault. The indicator light flashes 5 times each time, the flashing time is divided into two kinds of time: long time and short time, a long time is 1s which represents 1, and a short time is 0.2s which represents 0, the interval time is 0.5s, the interval time of each group is 3s.)

Fault Type	Fault Code	Fault Description
FAULT 00	00000	Open circuit of the combustion sensor
FAULT 01	00001	Load short circuit
FAULT 02	00010	The voltage of the power supply is too high
FAULT 03	00011	The voltage of the power supply is too low
FAULT 04	00100	Short circuit of the combustion sensor
FAULT 05	00101	Open circuit of the overheating sensor
FAULT 06	00110	Short circuit of the overheating sensor
FAULT 08	01000	The self-checking current for the electromagnetic pump is too large
FAULT 11	01011	Short circuit of the water temp. sensor
FAULT 12	01100	Open circuit of the water temp. sensor
FAULT 13	01101	Fail to ignite
FAULT 14	01110	Disruption in combustion
FAULT 18	10010	Open circuit of the ignition plug
FAULT 19	10011	The self-checking current for the ignition plug is too large
FAULT 21	10101	The self-checking current for the main motor is too large
FAULT 22	10110	The loop current for the water pump is too large
FAULT 25	11001	The air pressure value is too low
FAULT 26	11010	The air pressure value is too high
FAULT 27	11011	The heater is overheated
FAULT 29	11101	Motor rotation is not detected
FAULT 30	11110	Heater burns without cooling
FAULT 32	11111	Feedback signal is not detected